

CODE OPTIONS

CSD-1	STANDARD
--------------	----------

NOTE: Dimensions are approximate and should not be used to "rough-in" equipment.

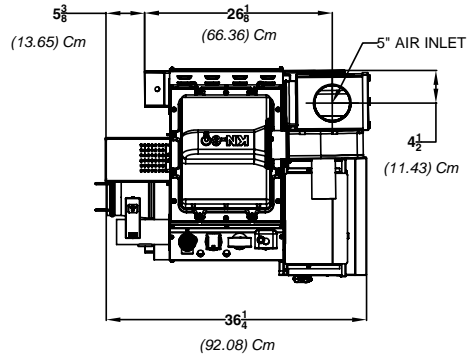

TOP VIEW

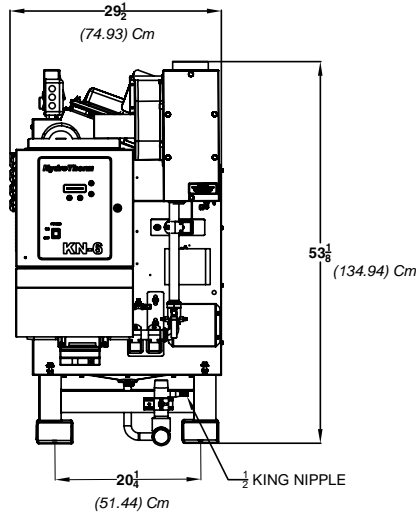

FRONT VIEW

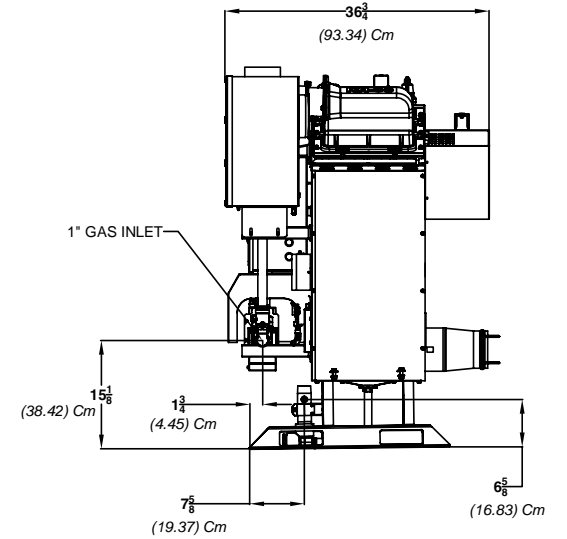

SIDE VIEW

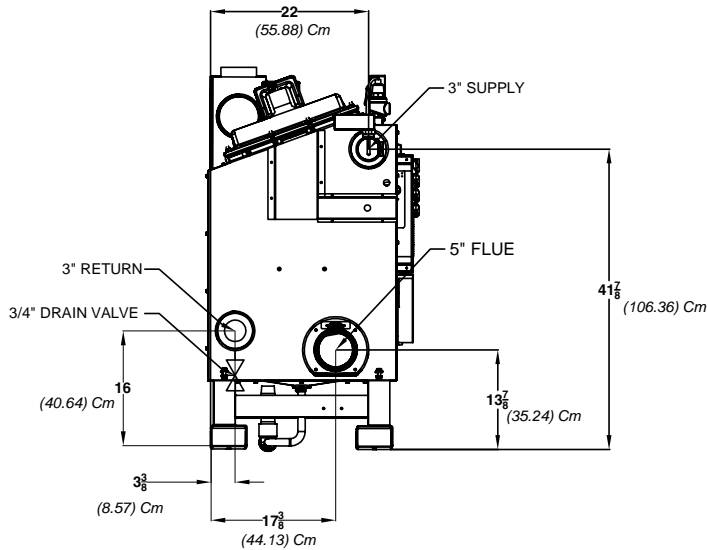

REAR VIEW

REP FIRM _____
SUBMITTED BY _____
JOB NAME _____
ARCHITECT _____
ENGINEER _____
CONTRACTOR _____
DATE _____

KN-6

Category II or Category IV Appliance
(see Installation and Operation Manual for venting information)

HydroTherm[®]

A Product of
ADVANCED THERMAL HYDRONICS
 A Division of Mestek, Inc.
 Westfield, MA 01085
 (413) 564-5515

A.G.A. CERTIFIED RATINGS & CAPACITIES

Fuel Type	Natural Gas	Boiler FLA	5 AMPS
Input BTU/hr.	600 MBH/ 176 KW	Min. Gas Pressure Required	2" W.C.
Output BTU/hr.	528* MBH/ 155 KW	Max. Gas Pressure Allowed	14" W.C.
Boiler HP	16	Water Volume	9.5 gal.
Electrical Requirements	120VAC/ 60 hz/ 1PH	Operating Weight	737 lbs. / 334 kg.

* Based on efficiency curve

BOILER TRIM & CONTROLS

Main Gas Valve	Dungs DMV-SE512/11	Manual Pilot Valve	Honeywell V8046C
Firing Valve	1" Apollo	Air Switch	Huba Type 605
Ignition Control	Honeywell RM7800	Blower Motor	Fasco 1/2 HP
Operating Control (FB/FW)	HeatNet™	L.W.C.O.	750P-MT-120
High Limit	Honeywell L4006E	Relief Valve - FW	30, 50, 75 & 100 PSI
Main Ball Valve	1" Apollo	Variable Speed Drive	KBVF-14
Pilot Cock	1/4" Conbraco	Pilot Regulator	MAXITROL RV12LT

TEMPERATURE RISE / PRESSURE DROP (Based on Full Input)

20° F / 11.1° C		40° F / 22.2° C		60° F / 33.3° C		80° F / 44.4° C		100° F / 55.5° C			
Flow Rate	Pressure Drop	Flow Rate	Pressure Drop	Flow Rate	Pressure Drop	Flow Rate	Pressure Drop	Flow Rate	Pressure Drop		
GPM	L/s	Ft	kPa	GPM	L/s	Ft	kPa	GPM	L/s	Ft	kPa
60.0	3.79	2.31	6.91	30.0	1.90	.58	1.73	20.0	1.26	.26	.78
15.0	.95	.14	.42	12.0	.78	.09	.27				

Flow GPM		Temp. Rise (°F)		Vent Length (Equiv. Ft.)		Air Inlet Length (Equiv. Ft.)	
Min	Max	Min	Max	Min	Max	Min	Max
10*	100	20	100	6	80	0	80

* At 100% input

A.S.M.E.

ASME Sect IV Htg Surface	21.168 Sq. Ft. / 1.97 Sq. M.	Design Data	100 PSI & 250° F
---------------------------------	------------------------------	--------------------	------------------

UNBALANCED FLUE LIMITATIONS

Negative Flue Pressure	-2" W.C.
-------------------------------	----------

