

ENG. NO. 73005-C
 PAT. NO. 5,203,496.
 5,323,960.
 6,637,668.
 7,140,394.

Thermostatic Water Controller Model 804 High-Low Water Mixer Unit No. 73005

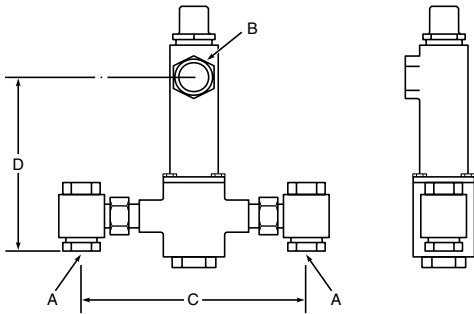

ASSE ASSE 1017 Approved



**Certified to
 CSA B125.3**

Master water mixing control valve shall be of the thermostatic type with liquid-filled motor. It shall have bronze body construction with replaceable corrosion-resistant components. Valve construction shall employ sliding piston control mechanism. Piston and liner shall be of stainless steel material. Valve shall come equipped with removable union end stop and check inlets with stainless steel strainers. Valve shall control temperature from a low flow of 4 GPM* up to a maximum flow rate for a given pressure differential. Valve shall provide protection against hot or cold supply line failure and thermostat failure.

DIMENSIONS:

Valve Number	A N.P.T.	B N.P.T.	C	D
804	1 1/2"	2"	15"	13 1/2"

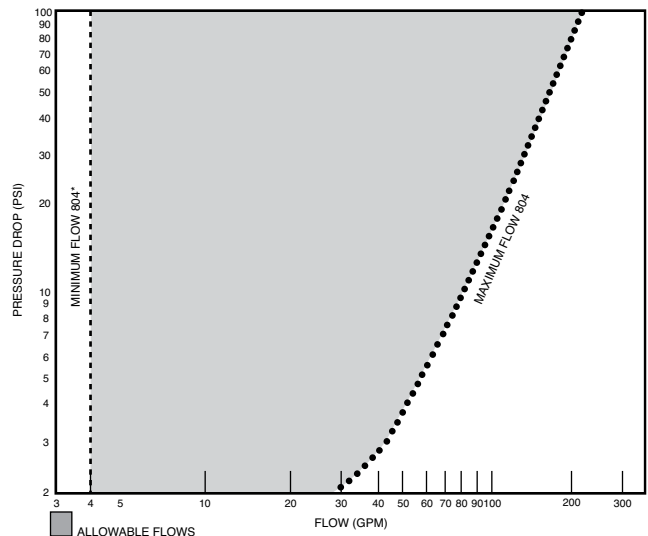

FINISH: Bronze
 Chrome
 Other

TEMP. RANGE **SET POINT**

70° to 100°F 80°F
 90° to 120°F 110°F
 110° to 140°F 130°F

Special _____

Optional Test Connection
 Including garden hose connection, shut-off and thermometer.

Bronze
 Chrome

CAPACITIES - MODEL 804

Pressure Drop PSI	5	10	20	30	45	60	80
Valve Number	Capacity						
804-GPM	52	72	100	124	150	174	193
804-LPM	197	273	379	469	568	659	731

*1/2 gpm when properly installed in recirculated system.



MANUFACTURING CO., INC.

5330 East 25th Street
 Indianapolis, Indiana 46218
 Phone (317) 261-1212
 Fax (317) 261-1208

Specification subject to change without notice.