

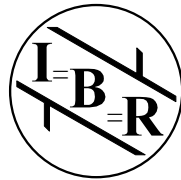

# FUTERA FUSION SERIES CONDENSING FINNED COPPER GAS BOILERS (MODELS CB) & WATER HEATERS (MODELS CW) OPTIONAL PVC VENT SYSTEM INSTALLATION INSTRUCTIONS SUPPLEMENT



These instructions are specific to using PVC pipe as the vent system for the RBI Fusion. The instructions contained in the Fusion Installation and Operation Manual, including all applicable Combustion Air & Ventilation and Venting instructions must be followed.

**WARNING: Venting of the Futera Fusion with PVC material requires the factory supplied PVC adapter kit. The vent system must conform to local codes and/or the latest edition of the National Fuel Gas Code ANSI Z223.1/NFPA 54. Failure to properly vent this product can result in CO poisoning causing severe personal injury or death!**

**NOTE: The return water temperature entering the Futera Fusion using the PVC venting option must not exceed 155°F. Higher return water temperatures will result in a reduction of the firing rate.**

The PVC vent adapter, Figure 1, comes fitted with a flue temperature sensor and flue temperature high limit switch. This system provides redundant over-temperature protection for the PVC vent system. The flue temperature sensor continuously monitors the temperature of the flue gas exiting the Fusion. If the return water temperature exceeds 155°F the HeatNet® Control, via the flue temperature sensor, will recognize the resultant increase in flue temperature and reduce the firing rate of the Fusion. Should the sensor fail, the manual reset high limit switch will trip and shut down the Fusion before the flue temperature can exceed a safe limit.

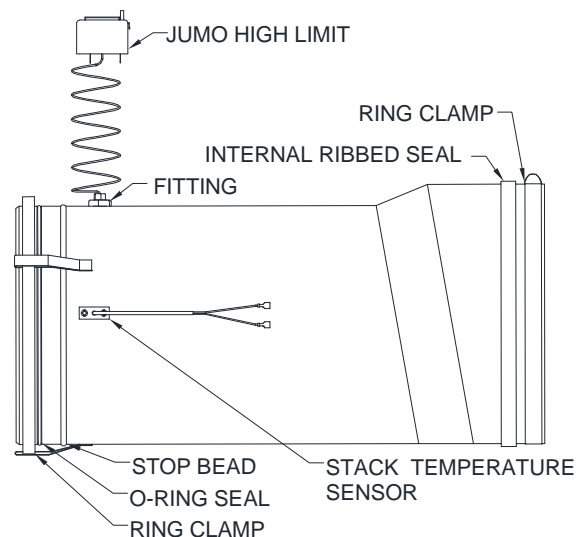

Figure 1

PVC Vent Adaptor

## PVC VENT ADAPTOR INSTALLATION

**CAUTION: Improper installation of the PVC vent adaptor can cause pooling of corrosive condensate and result in premature failure of the vent adaptor voiding the manufacturer's warranty!**

Remove the right rear jacket panel to gain access to the Fusion's economizer cabinet. With the PVC vent adaptor positioned at the rear of the unit carefully insert the manual reset high limit through the flue pipe opening

in the rear cabinet panel. Mount the high limit to the economizer bracket as shown in Figure 2.

**CAUTION: Do not kink or damage the high limit capillary tube or the limit may be ruined voiding the manufacturer’s warranty!**

Place the small end of the vent adaptor through the vent pipe opening in the rear cabinet panel. Position the vent adaptor so the high limit switch capillary is at the top of the adaptor, Figure 1.

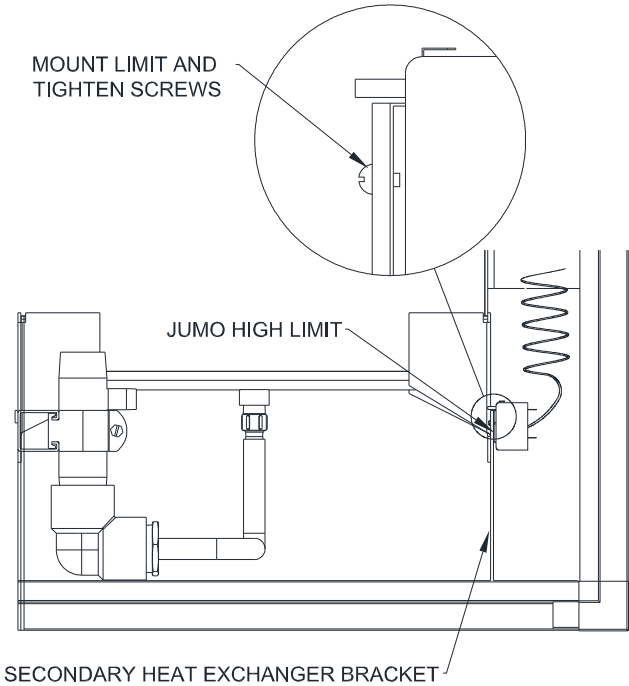

**Figure 2 PVC Vent Adaptor Installation**

Carefully push the vent adaptor into the vent collar until it bottoms against the stop bead on the adaptor and tighten the ring clamp to secure the vent adaptor to the Fusion vent collar, Figure 1.

**PVC VENT ADAPTOR WIRING**

**NOTICE: Failure to properly connect the flue temperature sensor and flue temperature high limit switch will prevent the Fusion from operating.**

Locate the wire harness inside the economizer cabinet. Connect the two wires with the 1/4" quick connects to the flue temperature high limit switch. Connect the two wires with the 3/16 quick connects to the flue temperature sensor.

**PVC VENT SYSTEM INSTALLATION**

The PVC vent adaptor has been engineered to directly accept PVC vent pipe. The internal gasket in the vent adaptor will form a gas and water tight seal. No glues or sealants are required at this connection. Slide the required horizontal length of PVC pipe into the vent adaptor and tighten the ring clamp to secure it in place.

The vent system must be sized per Table 1.

Model Size	Pipe Diameter	
	In	mm
500 - 1500	8	203
1750 – 2000	10	254

The maximum equivalent length for a positive pressure vent system is **60 ft, 18.3 m**. Each 90° elbow and the vent terminal are equal to **10 linear ft, 3.0 linear m** of pipe.

To maximize the performance of the vent system, locate 90° elbows as far from the Fusion and one another as possible.

When horizontal vent runs exceed **5 ft, 1.5m** they must be supported at **3 ft, 0.98 m** intervals with overhead hangers. The vent system must be pitched down, toward the vent terminal, **¼ in/ft, 21mm/m**.

If the vent system contains vertical sections horizontal vent runs between the Fusion and the vertical section must be pitched back, toward the economizer, **¼ in/ft, 21mm/m**, to prevent condensate from pooling in the vent.

**PVC VENT PIPE PREPARATION & ASSEMBLY**

1. Cut pipe ends squarely and remove all burrs, ridges and foreign matter using the appropriate tools and materials.

**NOTE: Failure to remove burrs or ridges will result in the cement in the fitting socket being scraped from the socket surface producing a dry joint which will have a high probability of failure.**

- 2. Before applying any cement dry fit pipe and fittings together to ensure that the parts fit properly.
- 3. Disassemble dry fitted parts and clean the pipe and fitting surfaces to be joined with a PVC cleaner. Surfaces to be joined must be free of dirt, moisture, oil and other foreign matter.

**WARNING: All primers, cleaners and cements must meet all local codes. Before using primers, cleaners and cements, stir or shake well, making sure the contents are liquid. Do not use if found to be lumpy or in a jelly-like state. Do not add solvents or thinners to reclaim thickened or lumpy material. Primers and cement should be NSF and/or UPC listed. Failure to use proper materials when venting this product can result in CO poisoning causing severe personal injury or death!**

**WARNING: Primers, cleaners and cements are extremely flammable and harmful or fatal if swallowed. Always store primers, cleaners and cements in a cool, dry, well ventilated place. Do not store them near heat, sparks or flames. Keep containers closed when not in use. Wear impervious clothing while handling. Do not smoke, eat or drink while handling primers, cleaners and cements. Wash thoroughly after handling and before eating. Wear eye protection when handling. The harmful vapors can be absorbed through the skin and may irritate eyes and skin. If inhaled, get fresh air and seek medical attention if ill feelings persist. In case of eye and/or skin contact, immediately flush with plenty of water for 15 minutes and seek medical attention if irritation persists. If swallowed, drink water, do not induce vomiting and call a physician or poison control center immediately. Failure to read and observe all safety information printed on primer, cleaner and cement containers can result in severe personal injury or death!**

**NOTE: Cleaners and primers are intended for different functions and should not be considered interchangeable. Verify with vent material manufacturer for specific requirements.**

4. Apply a coat of primer to the pipe and fitting surfaces that will be joined.
5. Apply a thin coat of cement to the fitting surface that will be joined making sure not over apply the cement which can cause puddling inside the fitting.
6. Apply a liberal coat of cement to the pipe surface that will be joined making sure to completely coat the area so it is free of voids.
7. QUICKLY assemble the parts while the cement is fluid! If the cement dries before the parts are assembled, re-coat the surfaces with cement then assemble them.
8. Push the end of the pipe completely into the fitting socket so it bottoms out and rotate the fitting or pipe at least ¼ turn to achieve proper cement spread. Make sure the parts are in the correct orientation before the cement cures. The cement bonds by melting the PVC so once the joint is made it cannot be disassembled.
9. Hold the pipe and fitting for 30 seconds to allow the joint to sufficiently cure then carefully clean off any excess cement with a cloth.
10. Follow the PVC cement manufacturer's instructions to allow the connections sufficient time to cure before putting any stress on the joint.

## PVC VENT TERMINALS

When vented horizontally the vent and air intake systems may be terminated using standard PVC fittings with 1/4" stainless steel bird-screen inserts as shown below. The minimum distance from the wall must be maintained as shown in the Figures below.

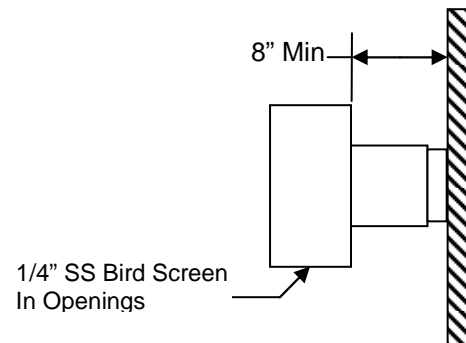

Figure 3

Horizontal PVC TEE Terminal

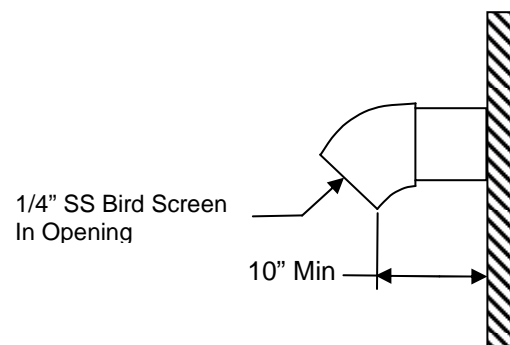

Figure 4

Horizontal PVC 45° Elbow Terminal

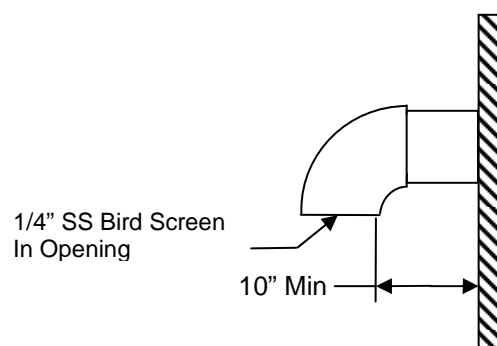
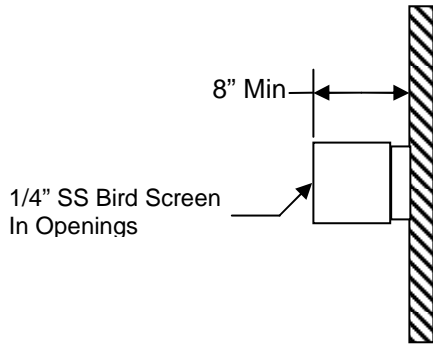

Figure 5

Horizontal PVC 90° Elbow Terminal



**Figure 6 Horizontal PVC Coupling Terminal**

The input of the unit must be set per Table 2 or nuisance shutdowns may occur under strong wind conditions.

**Table 1 Turn Down vs Combustion Air Source**

Terminal Type	Combustion Air	Turn Down Ratio
Tee	Indoor	3:1
Tee	Outdoor	4:1
45° Elbow	Indoor	n/a
45° Elbow	Outdoor	3:1
90° Elbow	Indoor	3:1
90° Elbow	Outdoor	4:1
Coupling	Indoor	3:1
Coupling	Outdoor	4:1

When vented vertically the vent and air intake systems should be terminated using standard 45° and 90° PVC Elbow fittings with a 1/4" stainless steel bird-screen insert as shown below.

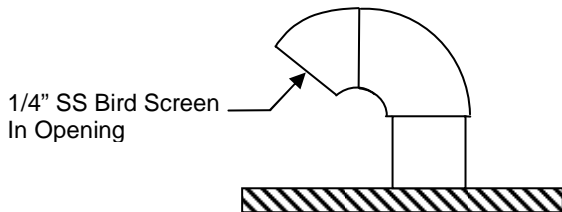

**Figure 7 Vertical PVC Terminal**

The rest of the applicable Combustion Air & Ventilation and Venting instructions contained in the INSTALLATION & OPERATION MANUAL **MUST BE FOLLOWED.**