

CODE OPTIONS

CSD-1	Manual Reset LWCO
Kentucky	200° F Maximum Operating Control and High Limit

NOTE: Dimensions are approximate and should not be used to "rough-in" equipment.

* Includes pump

** For incoming gas pressures lower than 2" W.C. natural or propane, consult factory.

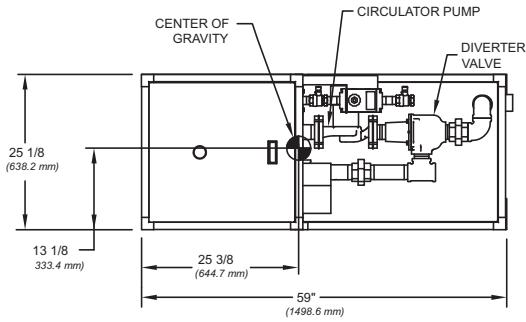

TOP VIEW

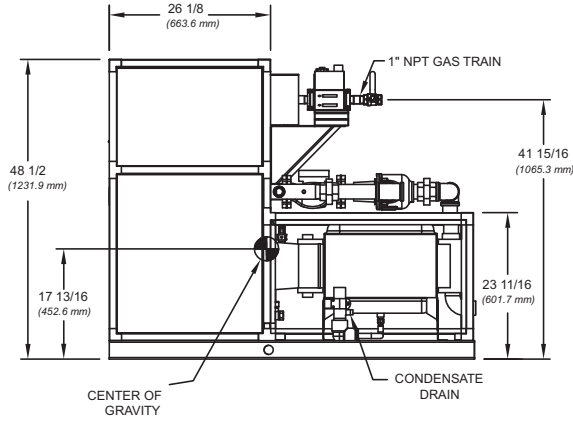

SIDE VIEW

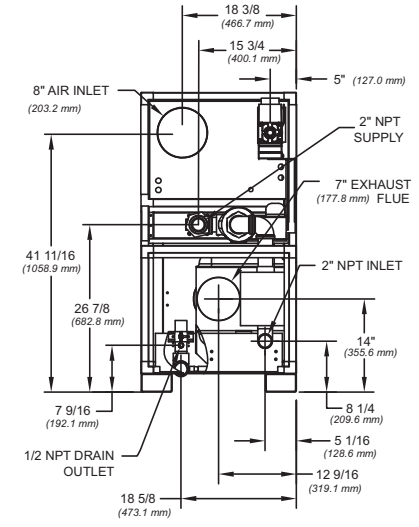

BACK VIEW

RSUB 96 REV. C

A.G.A. CERTIFIED RATINGS & CAPACITIES

Fuel Type	Natural/Propane Gas	Total FLA	9*
Input BTU/hr.	500,000 / 147 kW	Min. Gas Pressure Required	2" W.C.**
Output BTU/hr.	490,000 / 144 kW	Max. Gas Pressure Allowed	14" W.C.
Electrical Requirements	120VAC/ 1 ph/ 60 hz	Operating Weight	569 lbs. / 258 kg.

TEMPERATURE RISE / PRESSURE DROP

15° F / 8.3° C			
Flow Rate		Total Loss***	
GPM	L/s	Ft	kPa
58.0	3.7	8.8	26.3

***Includes primary, secondary, mixing valve and piping.

BOILER TRIM & CONTROLS

Main Gas Valve	Dungs DMV-SE512/11	Manual Pilot Valve	Honeywell V8046C
Firing Valve	Honeywell B200T1033 1"	Air Switch	Cleveland RSS-495
Ignition Control	Honeywell RM7895C	Blower Motor	Fasco 1/2 hp
Operating Control	HeatNet™	Relief Valve - CW	3/4" x 3/4" set @ 125 psi
High Limit	Jumo	Relief Valve - CB	3/4" x 3/4" set @ 50 psi
Main Ball Valve	1"	Flow Switch	IFS-1
Pilot Cock	1/4" Honeywell B528	Solenoid Valve w/ Reg	CV100
Economizer	RBI-1000	Circulator	TACO 1400 - 70 - FLA - 5
Mixing Valve	2"	By-Pass Piping	2"

RECOVERY CAPACITY

40°F	22° C	60°F	33° C	80°F	44° C	100°F	56° C	120°F	67° C	140°F	78° C
1471	5567	980	3711	735	2783	588	2227	490	1856	420	1591

A.S.M.E.

ASME Sect IV Htg Surface	69.51 Sq. Ft. / 6.46 Sq. M.	Design Data	Max. 160 psig & 250° F
Water Volume	3.4 gal. / 12.91 l (liters)	Secondary Heat Exchanger	125 psig
Water Volume Secondary HX	4.5 gal. / 17.03 l (liters)		

REP FIRM	_____	<p>FUTERA FUSION 500</p> <p>Category IV Appliance</p> <p>(see Installation and Operation Manual for venting information)</p> <p>® A Division of Mestek, Inc. Westfield, MA 01085 (413) 568-9571</p>
SUBMITTED BY	_____	
JOB NAME	_____	
ARCHITECT	_____	
ENGINEER	_____	
CONTRACTOR	_____	
DATE	_____	

SFTF-500-3