

CODE OPTIONS

CSD-1	Manual Reset LWCO
Kentucky	200° F Maximum Operating Control and High Limit

NOTE: Dimensions are approximate and should not be used to "rough-in" equipment.

* Includes pump
 ** For incoming gas pressures lower than 2" W.C. natural or propane, consult factory.

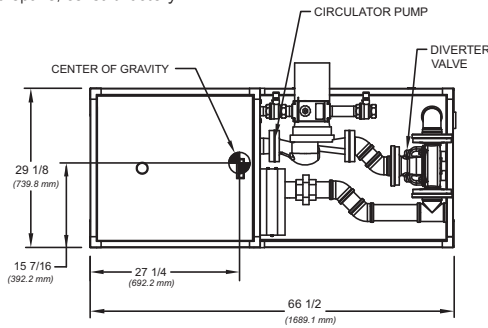

TOP VIEW

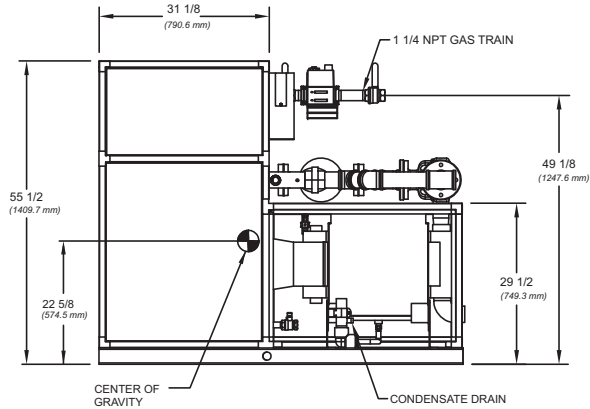

SIDE VIEW

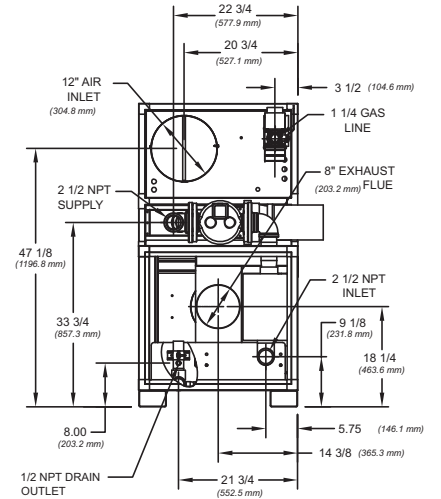

BACK VIEW

RSUB 99 REV. C

A.G.A. CERTIFIED RATINGS & CAPACITIES

Fuel Type	Natural/Propane Gas	Total FLA	16*
Input BTU/hr.	1,250,000 / 366 kW	Min. Gas Pressure Required	2" W.C.**
Output BTU/hr.	1,200,000 / 352 kW	Max. Gas Pressure Allowed	14" W.C.
Electrical Requirements	(L1,L2,NEU,GND) 208-240VAC/1 ph/60 Hz	Operating Weight	868 lbs. / 394 kg.

TEMPERATURE RISE / PRESSURE DROP

20° F / 11.1° C		25° F / 13.9° C					
Flow Rate	Total Loss***	Flow Rate	Total Loss***				
GPM	L/s	Ft	kPa				
108.8	6.9	11.6	34.7	87.0	5.5	8.2	24.4

***Includes primary, secondary, mixing valve and piping.

BOILER TRIM & CONTROLS

Main Gas Valve	Dungs DMV-SE512/11	Manual Pilot Valve	Honeywell V8046C
Firing Valve	Honeywell B200T1041 1 1/4"	Air Switch	Cleveland RSS-495
Ignition Control	Honeywell RM7895C	Blower Motor	Fasco 1 hp
Operating Control	HeatNet™	Relief Valve - CW	3/4" x 3/4" set @ 125 psi
High Limit	Jumo	Relief Valve - CB	3/4" x 1" set @ 50 psi
Main Ball Valve	1 1/4"	Flow Switch	IFS-1
Pilot Cock	1/4" Honeywell B528	Solenoid Valve w/ Reg	CV100
Economizer	RBI-1500	Circulator	TACO 1935 (3/4 hp) - FLA 11
Mixing Valve	2 1/2"	By-Pass Piping	2 1/2"

RECOVERY CAPACITY

40°F	22° C	60°F	33° C	80°F	44° C	100°F	56° C	120°F	67° C	140°F	78° C
3601	13,633	2401	9089	1801	6816	1441	5453	1200	4544	1029	3895

A.S.M.E.

ASME Sect IV Htg Surface	133.76 Sq. Ft. / 12.43 Sq. M.	Design Data	Max. 160 psig & 250° F
Water Volume	4.7 gal. / 17.79 l (liters)	Secondary Heat Exchanger	125 psi
Water Volume Secondary HX	5.96 gal. / 22.56 l (liters)		

REP FIRM	_____	<p>FUTERA FUSION 1250</p> <p>Category IV Appliance</p> <p>(see Installation and Operation Manual for venting information)</p> <p>RBI® A Division of Mestek, Inc. Westfield, MA 01085 (413) 568-9571</p>
SUBMITTED BY	_____	
JOB NAME	_____	
ARCHITECT	_____	
ENGINEER	_____	
CONTRACTOR	_____	
DATE	_____	