

CODE OPTIONS

CSD-1	Manual Reset LWCO
Kentucky	200° F Maximum Operating Control and High Limit

NOTE: Dimensions are approximate and should not be used to "rough-in" equipment.

* Includes pump

** For incoming gas pressures lower than 2" W.C. natural or propane, consult factory.

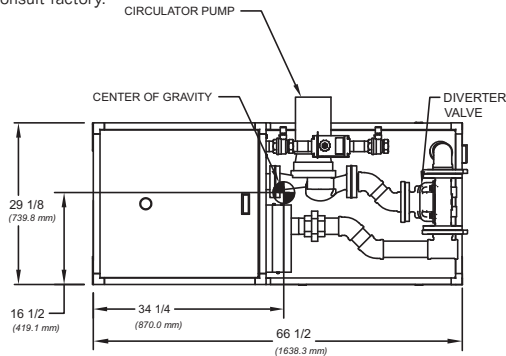

TOP VIEW

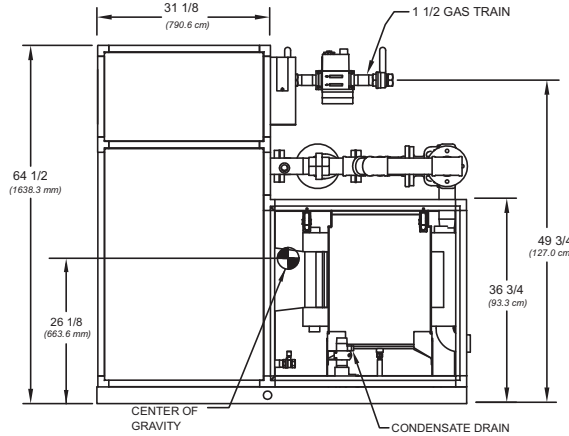

SIDE VIEW

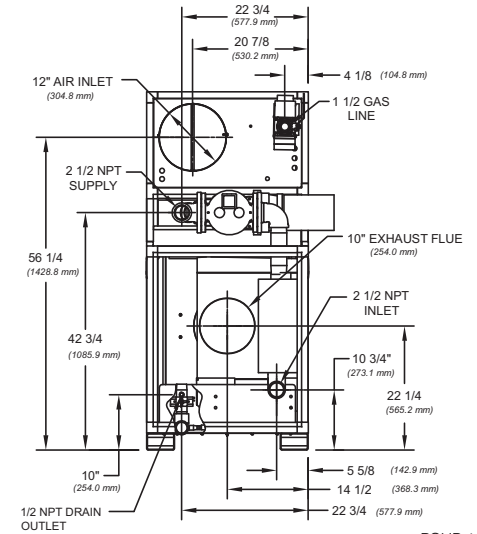

BACK VIEW

RSUB 101 REV. C

A.G.A. CERTIFIED RATINGS & CAPACITIES

Fuel Type	Natural/Propane Gas	Total FLA	21*
Input BTU/hr.	1,750,000 / 513 kW	Min. Gas Pressure Required	2" W.C.**
Output BTU/hr.	1,662,500 / 487 kW	Max. Gas Pressure Allowed	14" W.C.
Electrical Requirements	(L1,L2,NEU,GND) 208-240VAC/1 ph/60 hz	Operating Weight	1059 lbs. / 481 kg.

TEMPERATURE RISE / PRESSURE DROP

25° F / 13.9° C		30° F / 16.7° C	
Flow Rate	Total Loss***	Flow Rate	Total Loss***
GPM L/s	Ft kPa	GPM L/s	Ft kPa
121.8 7.7	14.7 43.9	101.5 6.4	10.6 31.7

***Includes primary, secondary, mixing valve and piping.

BOILER TRIM & CONTROLS

Main Gas Valve	Dungs DMV-SE512/11	Manual Pilot Valve	Honeywell V8046C
Firing Valve	Honeywell B200T1058 1 1/2"	Air Switch	Cleveland RSS-495
Ignition Control	Honeywell RM7895C	Blower Motor	Fasco 1 hp
Operating Control	HeatNet™	Relief Valve - CW	3/4" x 3/4" set @ 125 psi
High Limit	Jumo	Relief Valve - CB	1" x 1 1/4" set @ 50 psi
Main Ball Valve	1 1/2"	Flow Switch	IFS-1
Pilot Cock	1/4" Honeywell B528	Solenoid Valve w/ Reg	CV100
Economizer	RBI-2000	Circulator	TACO 1935 (1 hp) - FLA 14
Mixing Valve	2 1/2"	By-Pass Piping	2 1/2"

A.S.M.E.

ASME Sect IV Htg Surface	188.57 Sq. Ft. / 17.52 Sq. M.	Design Data	Max. 160 psig & 250° F
Water Volume	5.3 gal. / 20.06 l (liters)	Secondary Heat Exchanger	125 psi
Water Volume Secondary HX	7.07 gal. / 26.76 l (liters)		

RECOVERY CAPACITY

40°F	22° C	60°F	33° C	80°F	44° C	100°F	56° C	120°F	67° C	140°F	78° C
4989	18,887	3326	12,592	2495	9444	1996	7555	1663	6296	1426	5396

REP FIRM	_____	FUTERA FUSION 1750 Category IV Appliance (see Installation and Operation Manual for venting information)
SUBMITTED BY	_____	
JOB NAME	_____	
ARCHITECT	_____	
ENGINEER	_____	
CONTRACTOR	_____	
DATE	_____	RBI ® A Division of Mestek, Inc. Westfield, MA 01085 (413) 568-9571

SFTF-1750-3